

Application and Design:

The Model CD-100-RC was developed for air balancing at the mid/duct above inaccessible ceilings with adjustments at a terminal controller.

FPM Table

12" wide	- 2600 FPM
24"	- 2200
36"	- 2000
48"	- 1700

Pressure Limitations

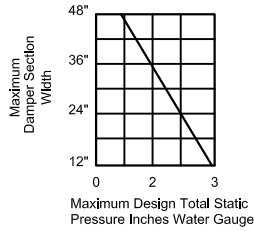

Rack & Pinion

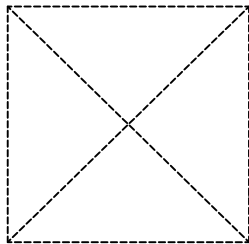
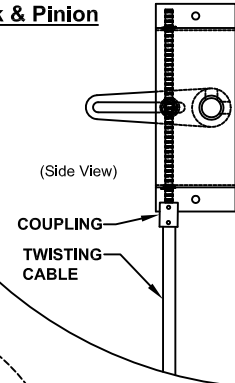

Twisting Cable encased in polyethylene tubing

Diffuser by others

Model 300 or 400

optional (Model 200)

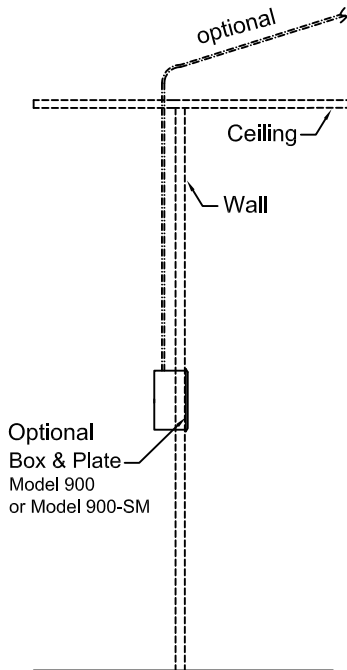

Optional Box & Plate Model 900 or Model 900-SM

Manufactured under license from owner of US Patent 5702298 & CN2185311

Model CD-100-RC (Rectangular Damper)

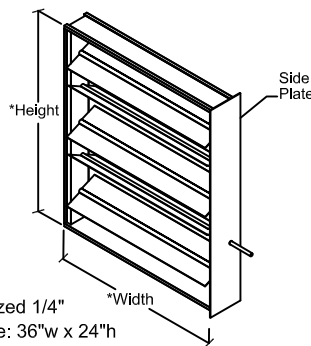

*Undersized 1/4"
 Max. Size: 36"w x 24"h

Features:

- Frame:** .081" Extruded Aluminum
 - Blade:** .125" Extruded Aluminum Exception-formed aluminum single blade thru 12" height
 - Bearings:** Bronze Oilite
 - Side Plate:** 6-1/4" x (ht. +1") x 18 ga galv. steel
 - Axles:** 1/2" dia. zinc plated steel with thrust bearing
- *No jamb seals*
 for performance see dwg. A-1 (CD-100)

RECOMMENDED SPECIFICATIONS

- A. Remote control system shall provide means of balancing airflow in ductwork above inaccessible ceilings
- B. In these areas, the contractor shall furnish and install Model CD-100-RC in the branch duct.
- C. The contractor shall furnish and install remote options of Model 200, 300, 400, 900, or 900-SM Controllers. Model 300 has zinc plated steel faceplate. Cable is capable of lengths of up to 60 feet.
- D. The contractor shall connect Twisting braided brass plated cable encased in polyethylene sheath from the damper to the terminal point.
- F. The Twisting Cable System shall be manufactured by United Enertech Corporation.

Due to continuing research, United Enertech reserves the right to change specifications without notice.

Options:

- Stainless Steel Construction
- 304 stainless 316 stainless

CABLE LENGTHS	
LENGTH	MAX. DAMPER SIZE
*10 ft.	48" x 48"
*12 ft.	40" x 40"
*14 ft.	36" x 36"
*18 ft.	24" x 24"
**up to 60 ft.	under 24" x 24"

*Cable clamps placed every 3 ft.
 **Cable clamps placed every 3 ft. or use conduit

Job Name:	DRAWN BY:	DATE:	REV. DATE:
Location:	CLJ	10-5-09	11-5-10
Architect:	REV. NO.	APPROVED BY:	DWG. NO.:
Engineer:	4	BGT	E-18
Contractor:			